

---

**ABSTRACT**

Present society is driven by knowledge and communication. Even pace of communication and fast access to event provides edge to several group of society. Information in modern era can't be communicated without multiple copies which is possible only through printing presses. Offset Printing presses are dominating the printing field in term of number of presses. Offset printing is consider as cheap, best and fast mode of reproducing posters, pamphlets, books, magazines/newspaper and many other advertising & publishing materials. In terms of offset printing time is the key. Offset presses were running in conventional mode and pre-press of such presses took much time, but adoption of CTP technology can reduce pre-press time significantly. So in war with time printer can make edge over others by adopting newer technologies. CTP is now available with almost all big printers but it is the time to understand the need of era and adopt this technology by medium and low end printers where plates are being consumed in good quantity.

**Keywords:** Offset surface preparation, CTP, Computer-to-Plate.

---

**INTRODUCTION**

Surface preparation of Offset printing is unique among all printing processes. Here image & non-image area lies on same plane and they are separated chemically. This property of chemical separation of image on same plane is not easily achievable. It needs several steps, materials, techniques, equipment's and skills to get it done with maximum accuracy. After preparation of pages, these are converted into negative/positive photographic films by exposing and developing. After that these films area assembled according to imposition and later by using flat plates are exposed (Steps explained in below figure).

Reduction of time in these operation leads to invention of CTF (Computer-to-Film), where negative/positive was prepared without any camera & Contact printer. Negative/ Positive prepared by CTF was used as flat for precreation of plates. To reduce further time taken in pre-press, CTP is invented, Wher films (Positive/Negative) are no longer needed for preparation of plates.

Computer to plate is a method of creating printing plates through a completely digital pre-press workflow. It is basically a type of pre-press process in which a digital image (complete imposition) is transmitted directly from a computer to a plate, which will used as printing surface for offset presses. As the process produces printing plate directly from the computer without requiring film, as an intermediate step the process is also known as direct to plate.

In a CTP system, digital information from a page file is sent in postscript from to an off-press CTP device known as a plate-setter, which reads the file information and exposes the data onto plate that are ready for press. As image is directly generated over the plates, so the process eliminates the need of films (Negative/Positive) and therefore, it also eliminates the steps related with films i.e; film separation, stripping, film-based proofs and shooting plates with flats.

The plates used in CTP systems are typically made of Aluminium, but now-a-days polyester, polymer and silicon plates are also used. Through this technology we can do off-press imaging as well as on-press imaging. Off-press imaging refers to using a plate setter to create the plate and then manually attaching the plates on the printing press for further printing. While on-press imaging the image are generated over the plate, which is already mounted on the press, and is known as direct-imaging (DI).

[Vandana\* *et al.*, 5(10): October, 2016]  
 ICTM Value: 3.00

CTP eliminates the cost of film & film related materials, that translates in to saving of time & money as well. Due to elimination of conventional & modern film making steps in CTF, CTP plates are imaged quickly, accurately and consistently. There are machines that can produce 100-250 plates per hour depending upon size and resolution of plates. One more big advantage which is less discussed and practiced is it can be operated without human intervention overnight if job is in sufficient quantity and cassette is full.

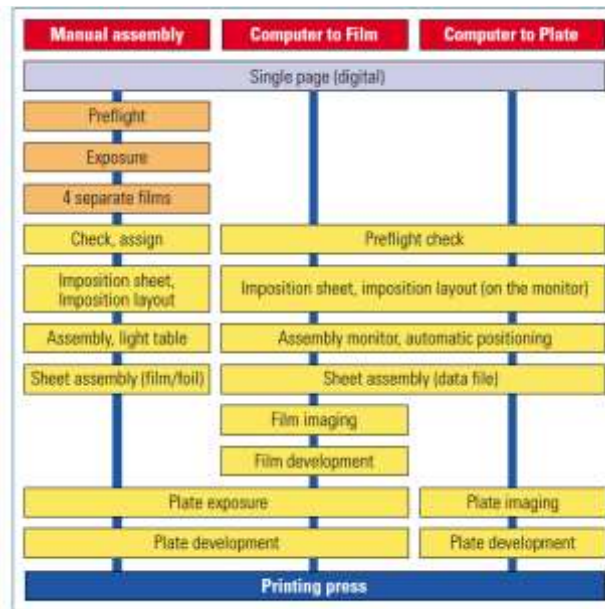

(Conventional Process, CTF & CTP work flow for Production of Plates for offset Printing)

**ELEMENTS OF COMPUTER-TO-PLATE (CTP)**

Computer to plate (CTP) consists of three basic components:

- (i) Computer / Work station
- (ii) Imaging System / Ripping software
- (iii) Printing Plate / Printing Surface

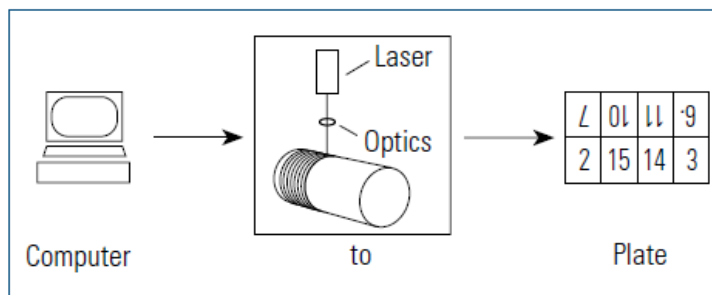

Basic Elements of Computer -to-plate

(A) **Computer / Workstation:** In modern era computer is backbone of any system, in CTP system it also has important role, because it influences the entire workflow. Application of computer results in substantial saving in time of manpower and ultimately cost of plate-making compared to conventional system.

(B) **Imaging system / Ripping Software:** The transfer of digital data to image the plate surface is performed by the ripping software central element of the CTP system of the plate-setter. In most systems laser are used for this purpose. The only thing should be taken care of power and wavelength of the laser beam which should be matched to the sensitivity of the plate surface. Irrespective of design of plate-setter Laser technology is used for imaging in most computers to plate system. The main source of imaging plate are:

- (i) Gas Laser
- (ii) Laser diodes
- (iii) UV light
- (iv) Ink Jet Imaging

(C) **Printing Plates/ Printing Surface:** Variety of surface/plates are available for CTP application. They vary with respect to the base, namely aluminium, polyester or paper. After imaging all plates are developed by means of solvent or water-based process.

### CONFIGURATION OF COMPUTER-TO-PLATE SYSTEM

Depending upon construction/design basically there are three types of CTP available for production of plates for offset/ flexography;

- (i) External drum system
- (ii) Internal drum system
- (iii) Flat bed system

#### (i) External Drum System

In the external drum system the plate is mounted on a drum. The imaging head focuses one or more laser beam on the plate surface. The drum rotates on which the plate is mounted and the imaging head moves along the axis of the drum.

The advantage of the external drum method over other imaging method is that both structurally and optically it is relatively easy to focus several Laser beams on the plate surface simultaneously. This leads to a corresponding reduction in imaging time for the entire plate. Fig 4 shows the drum and the imaging unit of the external drum CTP system. The external drum system is normally used in design of CTP system for imaging of flexographic plates.

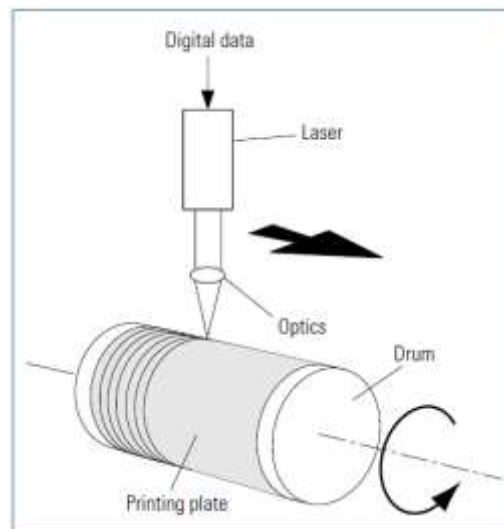

Design Principle of an external drum System

#### (ii) Internal Drum Design

The internal drum concept derives from the design of the film image setter. The printing plate is placed in a cylinder drum. Most device use angles greater than 180. There is a rotating mirror on the geometrical axis of the internal drum trough. The laser beam is reflected into the axis of the drum and deflected by rotating mirror onto the plate surface, which it scans in a circumferential direction. The optics with the rotating mirror move slowly in an axial direction. The rotating mirror rotates very fast. The number of rotations may be more than 40000 RPM.

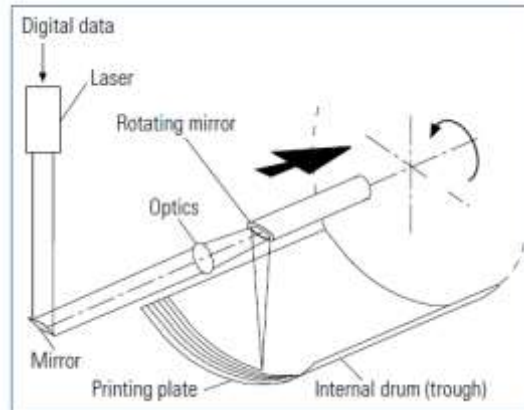

Design Principle of an external drum System

### (iii) Flat bed design

Flat bed design is simplest and most commonly used example of imaging technology. In this design the Laser beam is deflected line by line across the plate/substrate by rotating polygon mirror with imaging and correction optics.

In this design inspite of complicated optics, the dot generated in corner by Laser is less sharp and round than that in centre area of the plate because of this optical distortion, which increase with the format, flat-bed imagers are more suitable for smaller formats and stringent quality requirements (i.e. in Newspaper Production). The advantage of the flat-bed method is very easy handling of the plate. This leads to the relatively high number of flat-bed systems in newspaper production houses.

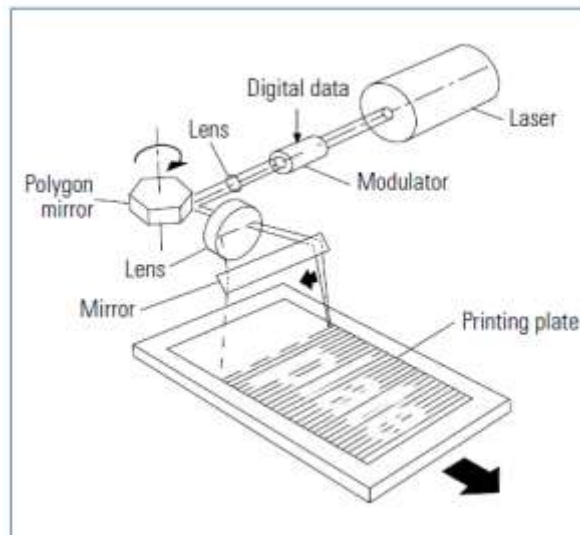

Design Principle of flat-bed System

### Computer-to-Plate (CTP) Workflow

The digitization of the workflow entailed by the introduction of CTP necessitates adaptation and possibly a complete conversion of previous conventional workflows.

Production house receives digital data from outside or another workstation, then first of all it will pass through “pre-flight check” in which it will be checked for completeness correctness and printability.

After imposition, the entire sheet, now available as a post script data, is usually sent to the raster image processor (RIP) for transforming into the bitmaps to be used. There are various solutions for transferring bitmap data from the RIP to the plate setter. In many CTP systems the imaging unit is directly connected to the RIP.

[Vandana\* *et al.*, 5(10): October, 2016]  
ICTM Value: 3.00

There is no intermediate storage for the bitmaps, but the data is transferred directly from the raster image processor (RIP) to the imaging head. While in other CTP system the imaging data (bitmaps) generated in the RIP is first stored in hard disk in a buffer memory.

There are devices for plate handling with varying degree of automation, such as those in which the plates have to be inserted in the safelight and removed from the plate-setter individually and at the other extreme those that grip the individual plate/substrate from the light-proof magazine automatically, remove the separating paper, and after exposure, pass the plate in-line to plate developing.

The diagram given below is of "Plate setter-3244", (courtesy- Handbook of Print Media) can be loaded with aluminium plate in one cassette and with polyester printing plate in other.

### Advantages of CTP

The advantages of CTP are that it removes one stage (several steps) from the convention pre-press process, which increases speed and accuracy along with the consistency of plate and quality as well. CTP also has the advantage of being registered in the machine and not relying on a pin or grid system as is the case of conventional pre-press and plate exposing device. Another advantage with CTP is that the problem related with dust and scratches are minimum. Furthermore, the process develop the plate are more environmentally safe as entire film exposing, development and other set of operation removed due to digital flow of data. CTP eliminates the cost of film and film related material that translate into saving of time and money as well.

Due to elimination of convention and modern film making steps in CTP process, plates are imaged quickly, accurately and consistently. There are machine that can produce 100-400 plates per hour depending on the size of resolution of the plates/image. One more big advantage which is less discussed and practiced is, it can be operated without any human intervention overnight if job is in sufficient quantity and cassette is full.

### Limitation of CTP

Apart from initial cost, CTP workflow is less compatible with conventional film based system, if some old work has to reproduce, entire digitization will be required or that set of plate will be prepared by convention method. If due to any reason one plate got cancelled in any set/job, all plates will have to be prepared again. CTP workflow is less compatible with film based system, if some old work/ re-print has to reproduce, entire digitization will be required or that set of plate will be prepared by conventional method. If due to any reason one plate of any set cancelled, all plates will have to be prepared again.

### CONCLUSION

Most of the commercial offset presses are running short of time due to various reasons. They are in war with time for meeting deadlines. Pre-press section is the most time consuming section in offset printing presses. By adopting CTP they will reduce their pre-press time by 90%. Speed, accuracy and consistency are the key factors and they pay back in first three years once installed. So for better quality hassle free printing CTP is must for all offset printing presses. Now-a-days CTP is not a luxury, it is essential equipment for running a good commercial printing press. It is pertinent to mention here that around 2000-2500 CTP are already installed across country, Most of them are installed with Newspaper printing presses, but by adopting this technology commercial printers can take lead also.

### ACKNOWLEDGEMENT

Authors are thankful to all the researchers, writers, managements and various professionals for their contributions and for their publication already exist on the same topics. Our purpose was to make this issue more general for easy understanding, adopting & promoting the knowledge and contribution of various authors on this topic by printers. However all credit goes to original researchers and if there is any copyright issue, please let us know, we will humbly acknowledge the same and we take corrective actions by withdrawing that from publication list.

### REFERENCES

- [1] **Handbook of Print Media, Technologies and Production Methods**, Helmut Kipphan, ISBN 3-540-67326-1, Springer – Verlag Baelin Heidelberg, New York.
- [2] **Offset Lithographic Technology** By Kenneth F. Hird Goodheart - Willcox Co., 2000



- 
- [3] **Printing Processes** By B.D. Mehendiratta
  - [4] **Graphic Technology: Process control for production of half-tone color separations, proof and production prints:** ISO 12647-7:2007.
  - [5] **Printing Technology** By J. Michael Adams, David D. Faux, Lloyd J. Rieber
  - [6] **Advances In Printing And Media Technology:** Vol. - XXXIII 2007, Vol. 33, 329-339 By: Fahlcrantz, Carl-Magnus, Kristoffer & Johansson
  - [7] **Lithographic Technology in transition** By Ervin A. Dennis, O. Odesina, DG Wilson Delmar Publishers, 1996
  - [8] **Letterpress Printing Process Part – I** by CS Misra
  - [9] **Letterpress Printing Process Part – II** by CS Misra
  - [10] **Art and Production** by N N Sarkar.